

1MHz, High-Efficiency, Step-Up Converter for White LEDs

Features

- **Wide Input Voltage from 2.5V to 6V**
- **0.2V Reference Voltage**
- **Fixed 1MHz Switching Frequency**
- **High Efficiency up to 88%**
- **100Hz to 200kHz PWM Brightness Control Frequency**
- **Open-LED Protection**
- **Under-Voltage Lockout Protection**
- **Over-Temperature Protection**
- **<1mA Quiescent Current During Shutdown**
- **TSOT-23-6A and TDFN2x2-8 Packages**
- **Lead Free and Green Devices Available (RoHS Compliant)**

Applications

- **White LED Display Backlighting**
- **Cell Phone and Smart Phone**
- **PDA, PMP, and MP3**
- **Digital Camera**

Simplified Application Circuit

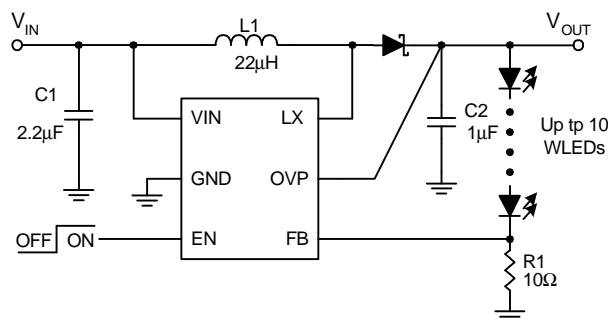

General Description

The APW7207/A is a current-mode and fixed frequency boost converter with an integrated N-FET to drive up to 10 white LEDs in series.

The series connection allows the LED current to be identical for uniform brightness. Its low on-resistance of N-FET and feedback voltage reduces power loss and achieves high efficiency. Fast 1MHz current-mode PWM operation is available for input and output capacitors and a small inductor while minimizing ripple on the input supply. The OVP pin monitors the output voltage and stops switching if exceeds the over-voltage threshold. An internal soft-start circuit eliminates the inrush current during start-up.

The APW7207/A also integrates under-voltage lockout, over-temperature protection, and current limit circuits. The APW7207/A is available in TSOT-23-6A and TDFN2x2-8 packages.

Pin Configuration

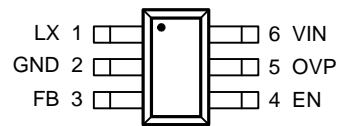

**TSOT-23-6A
(Top View)**

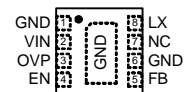

**TDFN 2x2-8
Top View**

ANPEC reserves the right to make changes to improve reliability or manufacturability without notice, and advise customers to obtain the latest version of relevant information to verify before placing orders.

Ordering and Marking Information

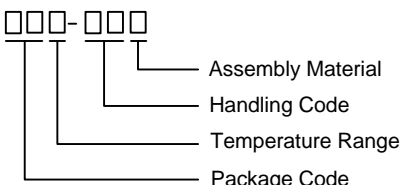
APW7207 APW7207A		Package Code CT : TSOT-23-6A QB: TDFN2x2-8 Operating Ambient Temperature Range I : -40 to 85 °C Handling Code TR : Tape & Reel Assembly Material G : Halogen and Lead Free Device	
APW7207 CT : <input type="text" value="W07X"/>	X - Date Code	APW7207A CT : <input type="text" value="W7AX"/>	X - Date Code
APW7207A QB : <input type="text" value="W07A"/>	X - Date Code		

Note: ANPEC lead-free products contain molding compounds/die attach materials and 100% matte tin plate termination finish; which are fully compliant with RoHS. ANPEC lead-free products meet or exceed the lead-free requirements of IPC/JEDEC J-STD-020D for MSL classification at lead-free peak reflow temperature. ANPEC defines "Green" to mean lead-free (RoHS compliant) and halogen free (Br or Cl does not exceed 900ppm by weight in homogeneous material and total of Br and Cl does not exceed 1500ppm by weight).

Absolute Maximum Ratings (Note 1)

Symbol	Parameter	Rating	Unit
V_{IN}	VIN Supply Voltage (VIN to GND)	-0.3 ~ 7	V
	FB, EN to GND Voltage	-0.3 ~ V_{IN}	V
V_{LX}	LX to GND Voltage	-0.3 ~ 42	V
V_{OVP}	OVP to GND Voltage	-0.3 ~ 42	V
T_J	Maximum Junction Temperature	150	°C
T_{STG}	Storage Temperature	-65 ~ 150	°C
T_{SDR}	Maximum Lead Soldering Temperature, 10 Seconds	260	°C

Note1: Stresses beyond those listed under "absolute maximum ratings" may cause permanent damage to the device. These are stress ratings only and functional operation of the device at these or any other conditions beyond those indicated under "recommended operating conditions" is not implied. Exposure to absolute maximum rating conditions for extended periods may affect device reliability.

Thermal Characteristics

Symbol	Parameter	Typical Value	Unit
θ_{JA}	Junction to Ambient Thermal Resistance. ^(Note 2)	TSOT-23-6A TDFN2x2-8	°C/W

Note 2: θ_{JA} is measured with the component mounted on a high effective thermal conductivity test board in free air.

Recommended Operating Conditions (Note 3)

Symbol	Parameter	Range	Unit
V_{IN}	VIN Input Voltage	2.5~ 6	V
V_{OUT}	Converter Output Voltage	Up to 42	V
C_{IN}	Input Capacitor	2.2 or higher	μF
C_{OUT}	Output capacitor	0.47 or higher	μF
L1	Inductor	6.8 ~ 22	μH
T_A	Ambient Temperature	-40 ~ 85	°C
T_J	Junction Temperature	-40 ~ 125	°C

Note 3: Refer to the application circuit for further information.

Electrical Characteristics

Refer to figure 1 in the "Typical Application Circuits". These specifications apply over $V_{IN} = 3.6V$, $T_A = -40 \sim 85^\circ C$ unless otherwise noted.

Symbol	Parameter	Test Conditions	APW7207/A			Unit
			Min.	Typ.	Max.	
SUPPLY VOLTAGE AND CURRENT						
V_{IN}	Input Voltage Range	$T_A = -40 \sim 85^\circ C$, $T_J = -40 \sim 125^\circ C$	2.5	-	6	V
I_{DD1}	Input DC bias current	$V_{FB} = 0.3V$, no switching	70	100	130	μA
I_{DD2}		FB = GND, switching	-	1	2	mA
I_{SD}		EN = GND	-	-	1	μA
UNDER VOLTAGE LOCKOUT						
	UVLO Threshold Voltage	V_{IN} Rising	2.0	2.25	2.48	V
	UVLO Hysteresis Voltage		50	100	150	mV
REFERENCE AND OUTPUT VOLTAGES						
V_{REF}	Regulated Feedback Voltage		190	200	210	mV
I_{FB}	FB Input Current		-50	-	50	nA
INTERNAL POWER SWITCH						
F_{SW}	Switching Frequency	FB=GND	0.8	1.0	1.2	MHz
R_{ON}	Power Switch On Resistance		-	0.6	1.2	Ω
I_{LIM}	Power Switch Current Limit		1.0	1.2	-	A
	LX Leakage Current	$V_{EN}=0V$, $V_{LX}=0V$ or $5V$, $V_{IN} = 5V$	-1	-	1	μA
D_{MAX}	LX Maximum Duty Cycle		92	95	98	%
OUTPUT OVER VOLTAGE PROTECTION						
V_{OVP}	Over Voltage Threshold	APW7207	23	25	27	V
		APW7207A	36	39	42	V
	OVP Hysteresis		1	-	4	V
	OVP Leakage Current	$V_{OVP} = 24V$	-	-	45	μA
ENABLE AND SHUTDOWN						
V_{TEN}	High-Level Input Voltage of EN		1	-	-	V
	Low-Level Input Voltage of EN		-	-	0.4	V
	EN Dimming Minimum On-time	$V_{EN}=3V$, PWM Dimming Frequency from 5k to 200kHz	-	0.6	-	μs
I_{LEN}	EN Leakage Current	$V_{EN} = 0\sim 5V$, $V_{IN} = 5V$	-1	-	1	μA
OVER-TEMPERATURE PROTECTION						
T_{OTP}	Over-Temperature Protection	T_J Rising	-	150	-	$^\circ C$
	Over-Temperature Protection Hysteresis		-	40	-	$^\circ C$

Typical Operating Characteristics

(Refer to figure 1 in the section "Typical Application Circuits", $V_{IN}=3.6V$, $T_A=25^\circ C$, 10WLEDs unless otherwise specified)

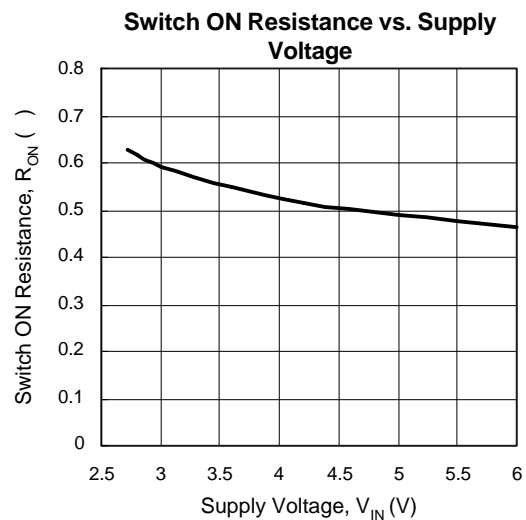
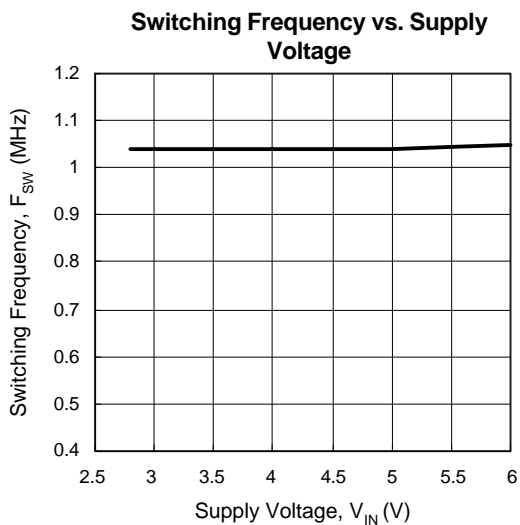
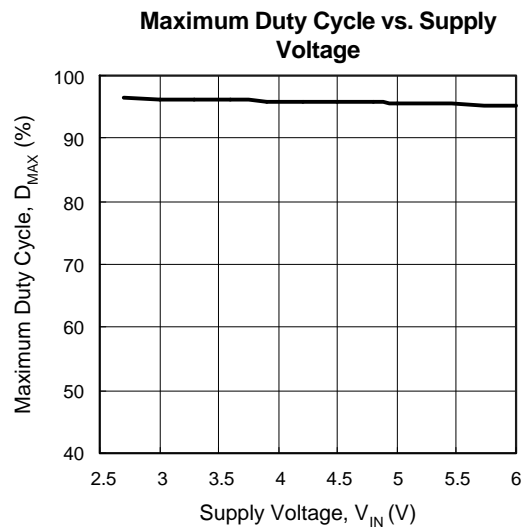
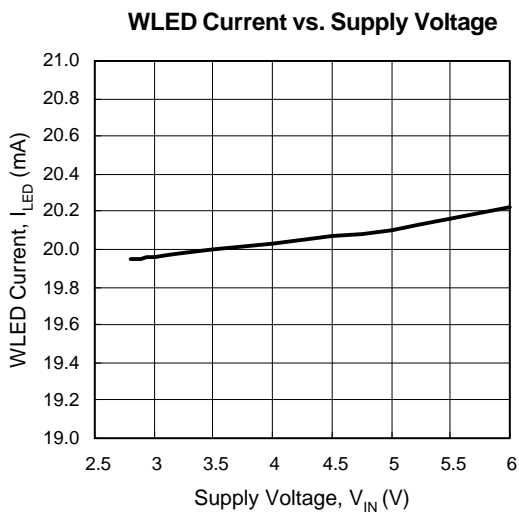
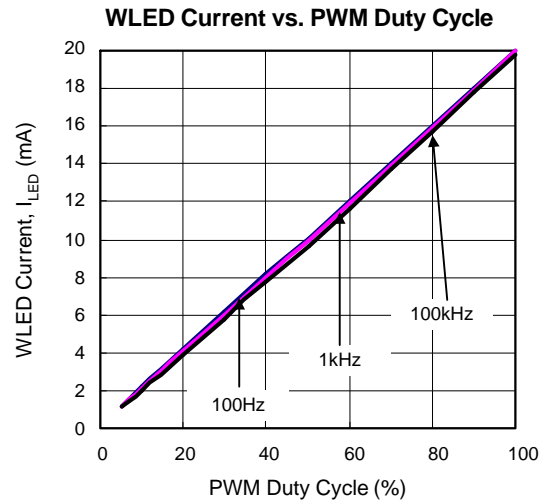
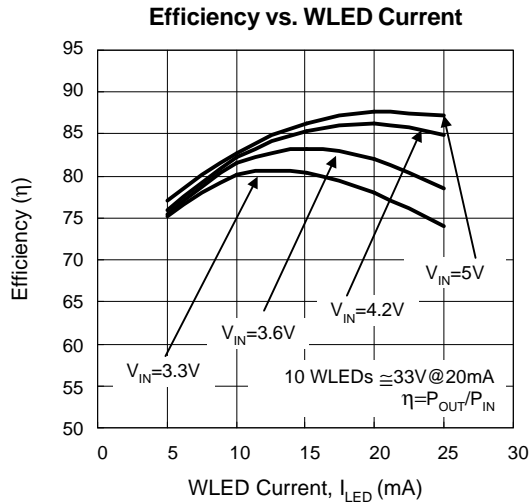

Operating Waveforms

(Refer to the application circuit in the section "Typical Application Circuits", $V_{IN}=3.6V$, $T_A=25^{\circ}C$, 10WLEDs unless otherwise specified)

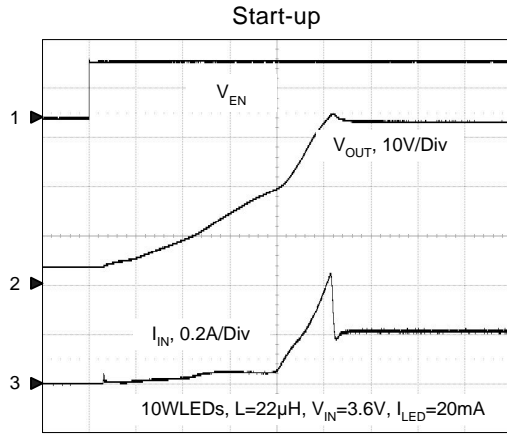

CH1: V_{EN} , 1V/Div, DC
CH2: V_{OUT} , 10V/Div, DC
CH3: I_{IN} , 0.2A/Div, DC
Time: 0.5ms/Div

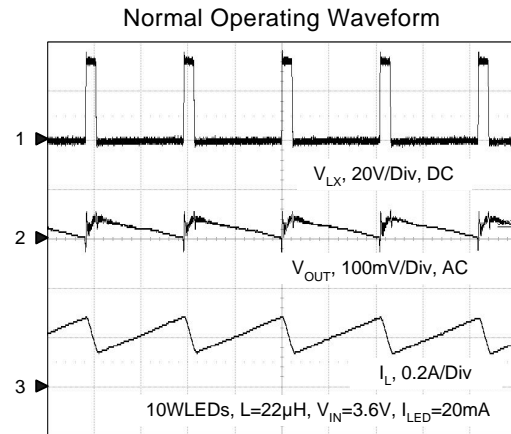

CH1: V_{LX} , 20V/Div, DC
CH2: V_{OUT} , 100mV/Div, AC
CH3: I_L , 0.2A/Div, DC
Time: 500ns/Div

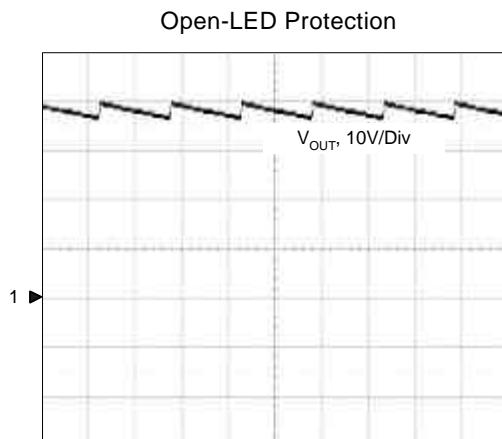

CH1: V_{OUT} , 10V/Div, DC
Time: 20ms/Div

Pin Description

PIN			FUNCTION
TSOT-23-6A	TDFN2x2-8	NAME	
1	8	LX	Switch pin. Connect this pin to inductor/diode here.
2	1,6	GND	Power and signal ground pin.
3	5	FB	Feedback Pin. Reference voltage is 0.2V. Connect this pin to cathode of the lowest LED and resistor (R1). Calculate resistor value according to $R1=0.2V/I_{LED}$.
4	4	EN	Enable Control Input. Forcing this pin above 1.0V enables the device, or forcing this pin below 0.4V to shut it down. In shutdown, all functions are disabled to decrease the supply current below 1 μ A. Do not leave this pin floating.
5	3	OVP	Over-Voltage Protection pin. OVP is connected to the output capacitor of the converter.
6	2	VIN	Main Supply Pin. Must be closely decoupled to the GND with a 2.2 μ F or greater ceramic capacitor.
-	7	NC	No Internal Connection.
-	Exposed Pad	GND	Connect this pad to GND.

Block Diagram

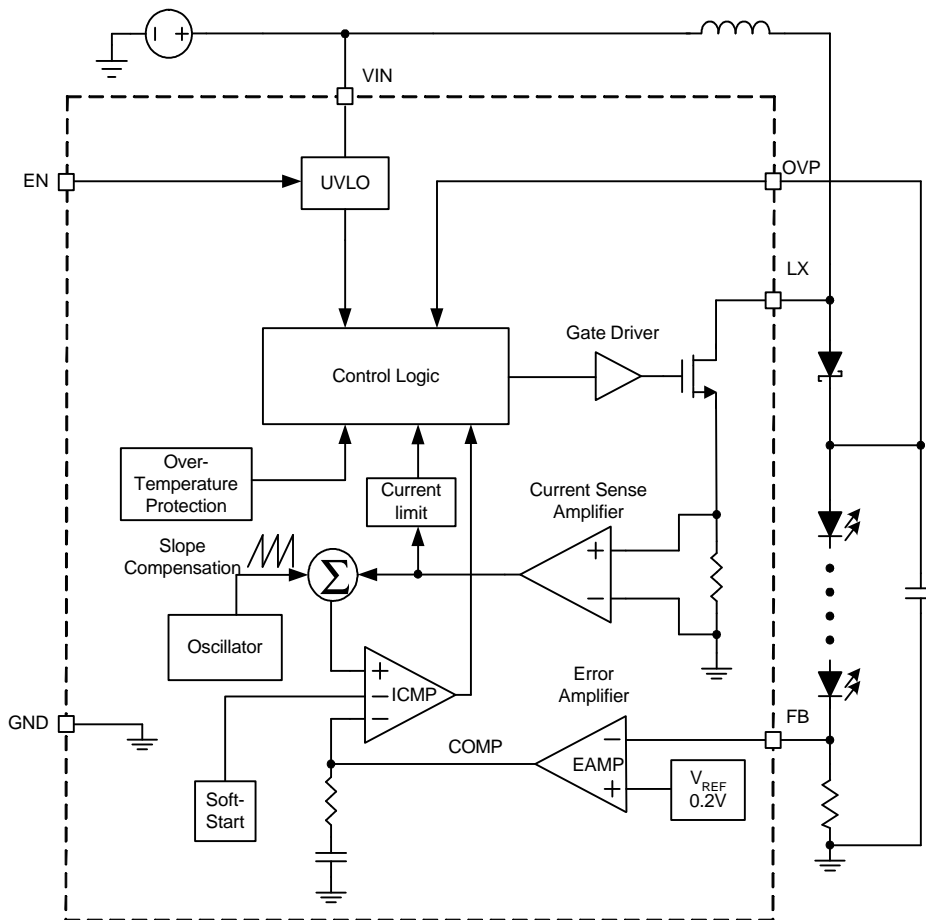

Typical Application Circuits

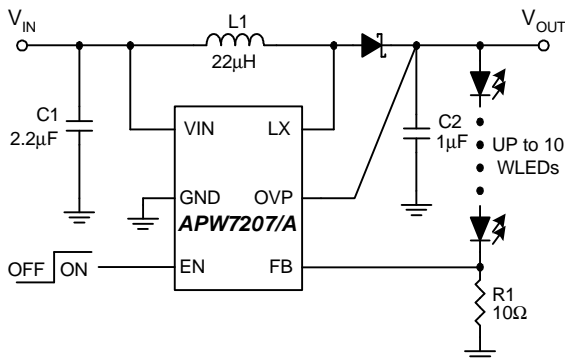

Figure 1. Typical 10 WLEDs Application

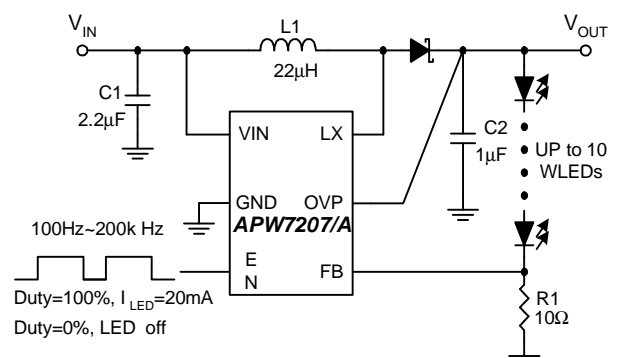

Figure 2. Brightness control using a PWM signal applies to EN

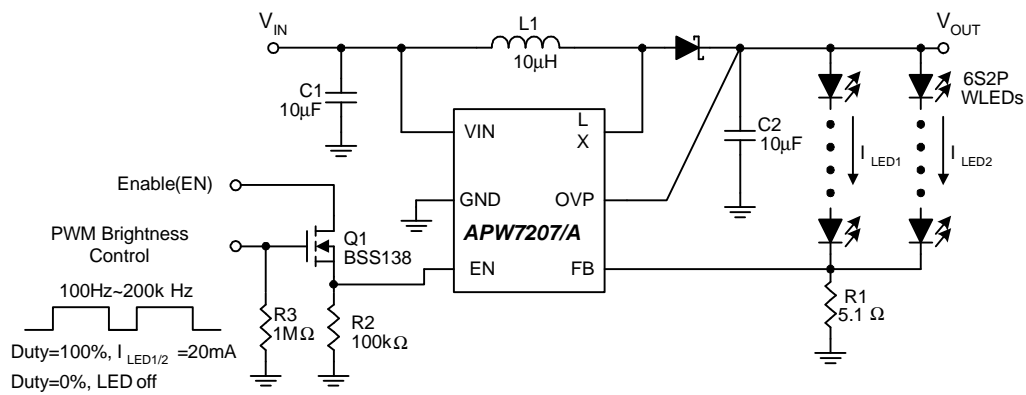

Figure 3. Separate Enable and PWM Brightness Control Using a MOSFET

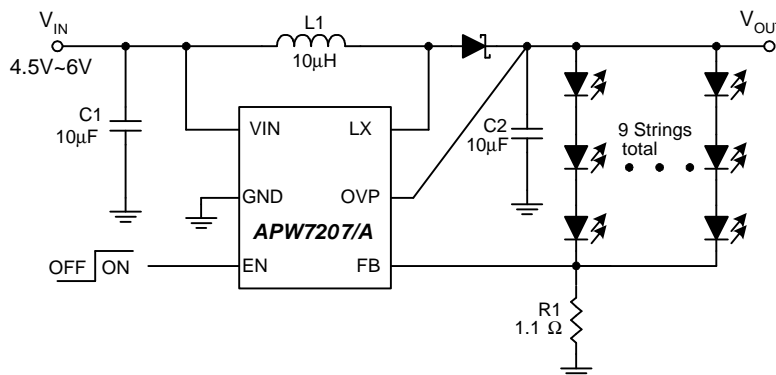

Figure 4. Circuit for driving 27 WLEDs

Function Description

Main Control Loop

The APW7207/A is a constant frequency current-mode switching regulator. During normal operation, the internal N-channel power MOSFET is turned on each cycle when the oscillator sets an internal RS latch and turned off when an internal comparator (ICMP) resets the latch. The peak inductor current at which ICMP resets the RS latch is controlled by the voltage on the COMP node, which is the output of the error amplifier (EAMP). An external resistive divider connected between V_{OUT} and ground allows the EAMP to receive an output feedback voltage V_{FB} at FB pin. When the load current increases, it causes a slightly decrease in V_{FB} relative to the 0.2V reference, which in turn causes the COMP voltage to increase until the average inductor current matches the new load current.

VIN Under-Voltage Lockout (UVLO)

The Under-Voltage Lockout (UVLO) circuit compares the input voltage at VIN with the UVLO threshold (2.3V rising, typical) to ensure the input voltage is high enough for reliable operation. The 100mV (typ) hysteresis prevents supply transients from causing a restart. Once the input voltage exceeds the UVLO rising threshold, start-up begins. When the input voltage falls below the UVLO falling threshold, the controller turns off the converter.

Soft-Start

The APW7207/A has a built-in soft-start to control the N-channel MOSFET current rise during start-up. During soft-start, an internal ramp, connected to one of the inverting inputs, raise up to replace the output voltage of error amplifier until the ramp voltage reaches the V_{COMP} .

Current-Limit Protection

The APW7207/A monitors the inductor current, flowing through the N-channel MOSFET, and limits the current peak at current-limit level to prevent loads and the APW7207/A from damages during overload or short-circuit conditions.

Over-Temperature Protection (OTP)

The over-temperature circuit limits the junction temperature of the APW7207/A. When the junction temperature exceeds 150°C, a thermal sensor turns off the power MOSFET, allowing the devices to cool. The thermal sensor allows the converters to start a soft-start process and regulate the output voltage again after the junction temperature cools by 40°C. The OTP is designed with a 40°C hysteresis to lower the average Junction Temperature (T_J) during continuous thermal overload conditions, increasing the lifetime of the device.

Enable/Shutdown

Driving EN to ground places the APW7207/A in shutdown mode. When in shutdown, the internal power MOSFET turns off, all internal circuitry shuts down and the quiescent supply current reduces to 1μA maximum.

This pin also could be used as a digital input allowing brightness control using a PWM signal from 100Hz to 200kHz. The 0% duty cycle of PWM signal corresponds to zero LEDs current and 100% corresponds to full one.

Open-LED Protection

In driving LED applications, the feedback voltage on FB pin falls down if one of the LEDs, in series, is failed. Meanwhile, the converter unceasingly boosts the output voltage like a open-loop operation. Therefore, an over-voltage protection (OVP), monitoring the output voltage via OVP pin, is integrated into the chip to prevent the LX and the output voltages from exceeding their maximum voltage ratings. When the voltage on the OVP pin rises above the OVP threshold, the converter stops switching and prevents the output voltage from rising. The converter can work again when the falling OVP voltage falls below the OVP voltage threshold.

Application Information

Input Capacitor Selection

The input capacitor (C_{IN}) reduces the ripple of the input current drawn from the input supply and reduces noise injection into the IC. The reflected ripple voltage will be smaller when an input capacitor with larger capacitance is used. For reliable operation, it is recommended to select the capacitor with maximum voltage rating at least 1.2 times of the maximum input voltage. The capacitors should be placed close to the VIN and GND.

Inductor Selection

Selecting an inductor with low dc resistance reduces conduction losses and achieves high efficiency. The efficiency is moderated whilst using small chip inductor which operates with higher inductor core losses. Therefore, it is necessary to take further consideration while choosing an adequate inductor. Mainly, the inductor value determines the inductor ripple current: larger inductor value results in smaller inductor ripple current and lower conduction losses of the converter. However, larger inductor value generates slower load transient response. A reasonable design rule is to set the ripple current, ΔI_L , to be 30% to 50% of the maximum average inductor current, $I_{L(AVG)}$. The inductor value can be obtained as below,

$$L \geq \left(\frac{V_{IN}}{V_{OUT}} \right)^2 \times \frac{V_{OUT} - V_{IN}}{F_{SW} \cdot I_{OUT(MAX)}} \times \frac{\eta}{\left(\frac{\Delta I_L}{I_{L(AVG)}} \right)}$$

where

- V_{IN} = input voltage
- V_{OUT} = output voltage
- F_{SW} = switching frequency in MHz
- I_{OUT} = maximum output current in amp.
- η = Efficiency
- $\Delta I_L / I_{L(AVG)}$ = inductor ripple current/average current
(0.3 to 0.5 typical)

To avoid the saturation of the inductor, the inductor should be rated at least for the maximum input current of the converter plus the inductor ripple current. The maximum input current is calculated as below:

$$I_{IN(MAX)} = \frac{I_{OUT(MAX)} \cdot V_{OUT}}{V_{IN} \cdot \eta}$$

The peak inductor current is calculated as the following equation:

$$I_{PEAK} = I_{IN(MAX)} + \frac{1}{2} \cdot \frac{V_{IN} \cdot (V_{OUT} - V_{IN})}{V_{OUT} \cdot L \cdot F_{SW}}$$

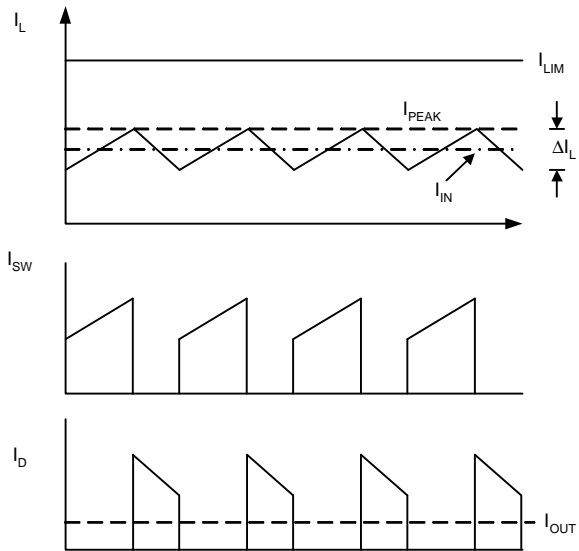
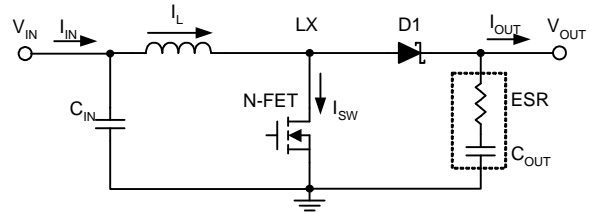

Output Capacitor Selection

The current-mode control scheme of the APW7207/A allows the usage of tiny ceramic capacitors. The higher capacitor value provides good load transients response. Ceramic capacitors with low ESR values have the lowest output voltage ripple and are recommended. If required, tantalum capacitors may be used as well. The output ripple is the sum of the voltages across the ESR and the ideal output capacitor.

$$V_{OUT} = V_{ESR} + V_{COUT}$$

$$\Delta V_{COUT} \approx \frac{I_{OUT}}{C_{OUT}} \cdot \left(\frac{V_{OUT} - V_{IN}}{V_{OUT} \cdot F_{SW}} \right)$$

$$\Delta V_{ESR} \approx I_{PEAK} \cdot R_{ESR}$$

where I_{PEAK} is the peak inductor current.

Application Information (Cont.)

Output Capacitor Selection (Cont.)

For ceramic capacitor application, the output voltage ripple is dominated by the ΔV_{COUT} . When choosing the input and output ceramic capacitors, the X5R or X7R with their good temperature and voltage characteristics are recommended.

Diode Selection

To achieve high efficiency, a Schottky diode must be used. The current rating of the diode must meet the peak current rating of the converter.

Setting the LED Current

In figure 1, the converter regulates the voltage on FB pin, connected with the cathod of the lowest LED and the current-sense resistor R1, at 0.2V (typical). Therefore, the current (I_{LED}), flowing via the LEDs and the R1, is calculated by the following equation:

$$I_{\text{LED}} = 0.2V/R1$$

Recommended Inductor Selection

Designator	Manufacturer	Part Number	Inductance (μH)	Max DCR (Ω)	Saturation Current (A)	Dimensions L x W x H (mm^3)
L1	GOTREND	GTSD-53-100	10	0.09	1.3	5 x 5 x 3

Recommended Capacitor Selection

Designator	Manufacturer	Part Number	Capacitance (μF)	TC Code	Rated Voltage (V)	Case size
C1	Murata	GRM188C70J225KE20	2.2	X7S	6.3	0603
C1	Murata	GRM219C80J106KE39	10	X6S	6.3	0805
C2	Murata	GRM21BR71H105KA12	1.0	X7R	50	0805
C2	Murata	GRM31CR61E106KA12	10	X5R	25	1206

Recommended Diode Selection

Designator	Manufacturer	Part Number	Maximum average forward rectified current (A)	Maximum repetitive peak reverse voltage (V)	Case size
D1	Zowie	MSCD104	1.0	40	0805

Application Information (Cont.)

Layout Consideration

For all switching power supplies, the layout is an important step in the design; especially at high peak currents and switching frequencies. If the layout is not carefully done, the regulator might show noise problems and duty cycle jitter.

1. The input capacitor should be placed close to the VIN and GND. Connecting the capacitor with VIN and GND pins by short and wide tracks without using any vias for filtering and minimizing the input voltage ripple.
2. The inductor should be placed as close as possible to the LX pin to minimize length of the copper tracks as well as the noise coupling into other circuits.
3. Since the feedback pin and network is a high impedance circuit, the feedback network should be routed away from the inductor. The feedback pin and feedback network should be shielded with a ground plane or track to minimize noise coupling into this circuit.
4. A star ground connection or ground plane minimizes ground shifts and noise is recommended.

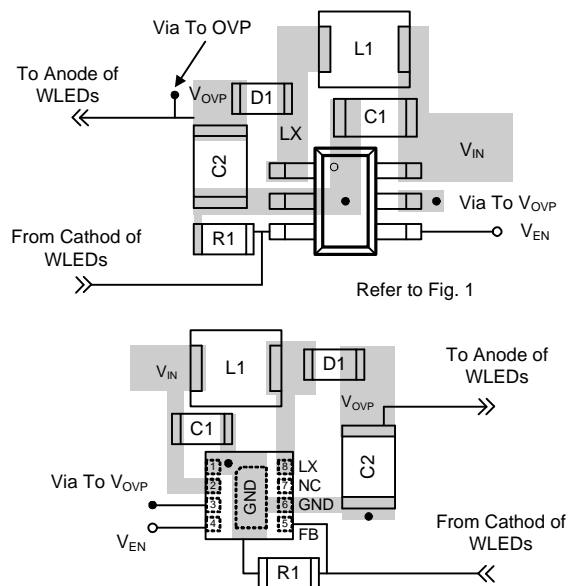
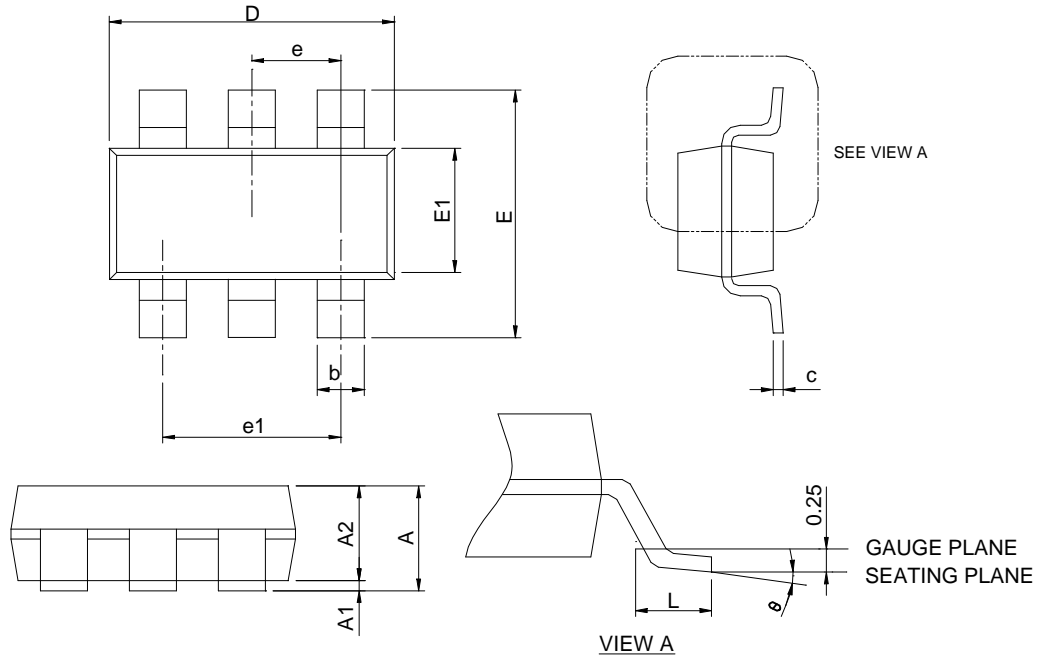

Fig 4. APW7207/A Layout Suggestion

Package Information

TSOT-23-6A



DIMENSIONS	TSOT-23-6A			
	MILLIMETERS		INCHES	
	MIN.	MAX.	MIN.	MAX.
A	0.70	1.00	0.028	0.039
A1	0.01	0.10	0.000	0.004
A2	0.70	0.90	0.028	0.035
b	0.30	0.50	0.012	0.020
c	0.08	0.20	0.003	0.008
D	2.70	3.10	0.106	0.122
E	2.60	3.00	0.102	0.118
E1	1.40	1.80	0.055	0.071
e	0.95 BSC		0.037 BSC	
e1	1.90 BSC		0.075 BSC	
L	0.30	0.60	0.012	0.024
θ	0°	8°	0°	8°

Note : Dimension D and E1 do not include mold flash, protrusions or gate burrs. Mold flash, protrusion or gate burrs shall not exceed 10 mil per side.

Package Information

TDFN2x2-8

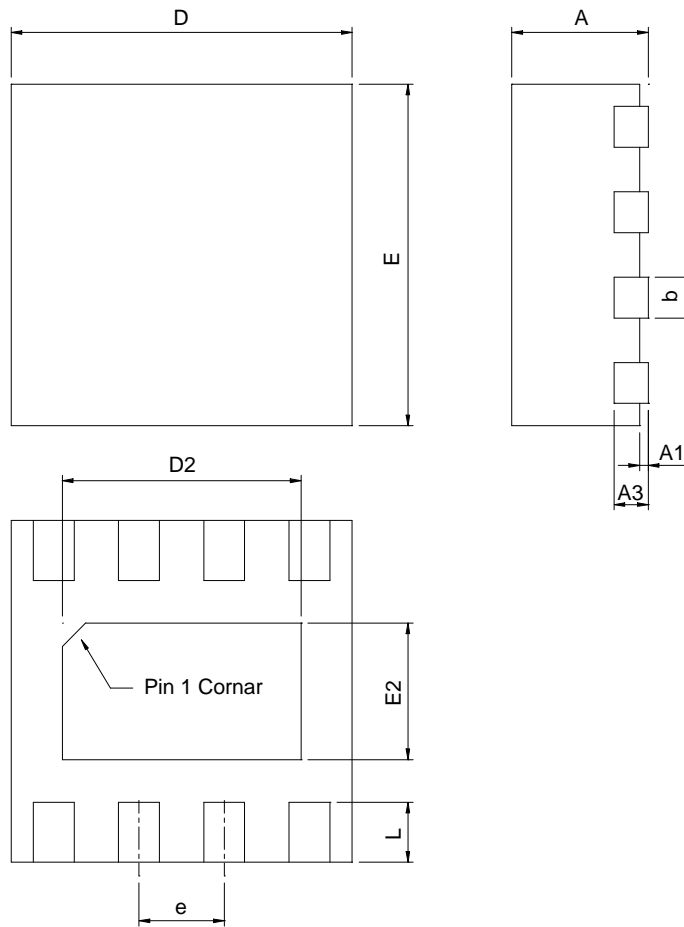

SYMBOL	TDFN2x2-8			
	MILLIMETERS		INCHES	
	MIN.	MAX.	MIN.	MAX.
A	0.70	0.80	0.028	0.031
A1	0.00	0.05	0.000	0.002
A3	0.20 REF		0.008 REF	
b	0.18	0.30	0.007	0.012
D	1.90	2.10	0.075	0.083
D2	1.00	1.60	0.039	0.063
E	1.90	2.10	0.075	0.083
E2	0.60	1.00	0.024	0.039
e	0.50 BSC		0.020 BSC	
L	0.30	0.45	0.012	0.018

Note : 1. Followed from JEDEC MO-229 WCCD-3.

Carrier Tape & Reel Dimensions

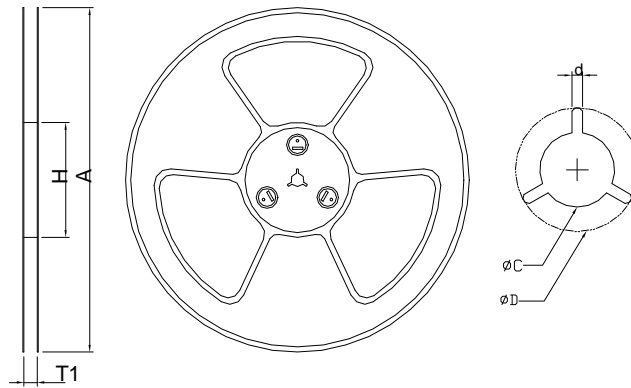
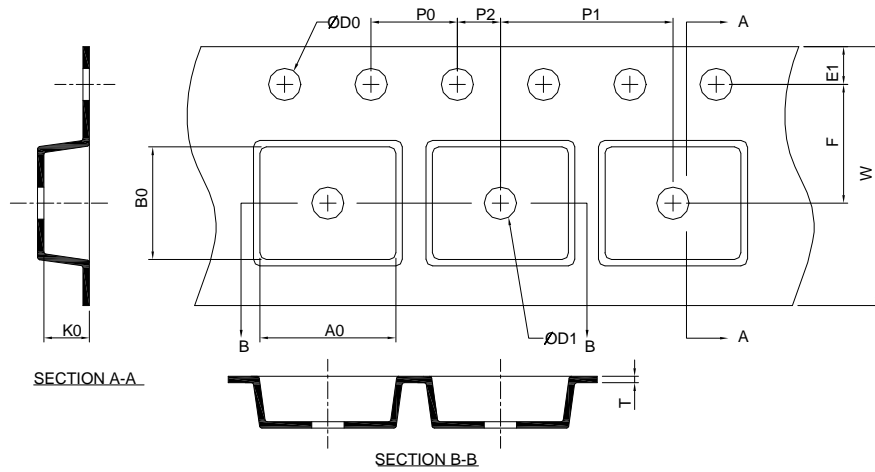

Application	A	H	T1	C	d	D	W	E1	F
TSOT-23-6A	178.0 ±2.00	50 MIN.	8.4+2.00 -0.00	13.0+0.50 -0.20	1.5 MIN.	20.2 MIN.	8.0 ±0.30	1.75 ±0.10	3.5 ±0.05
	P0	P1	P2	D0	D1	T	A0	B0	K0
	4.0 ±0.10	4.0 ±0.10	2.0 ±0.05	1.5+0.10 -0.00	1.0 MIN.	0.6+0.00 -0.40	3.20 ±0.20	3.10 ±0.20	1.50 ±0.20
Application	A	H	T1	C	d	D	W	E1	F
TDFN2x2-8	178.0 ±2.00	50 MIN.	8.4+2.00 -0.00	13.0+0.50 -0.20	1.5 MIN.	20.2 MIN.	8.0 ±0.20	1.75 ±0.10	3.50 ±0.05
	P0	P1	P2	D0	D1	T	A0	B0	K0
	4.0 ±0.10	4.0 ±0.10	2.0 ±0.05	1.5+0.10 -0.00	1.5 MIN.	0.6+0.00 -0.4	3.35 MIN	3.35 MIN	1.30 ±0.20

(mm)

Devices Per Unit

Package Type	Unit	Quantity
TDFN2x2-8	Tape & Reel	3000
TSOT-23-6A	Tape & Reel	3000

Taping Direction Information

TSOT-23-6A

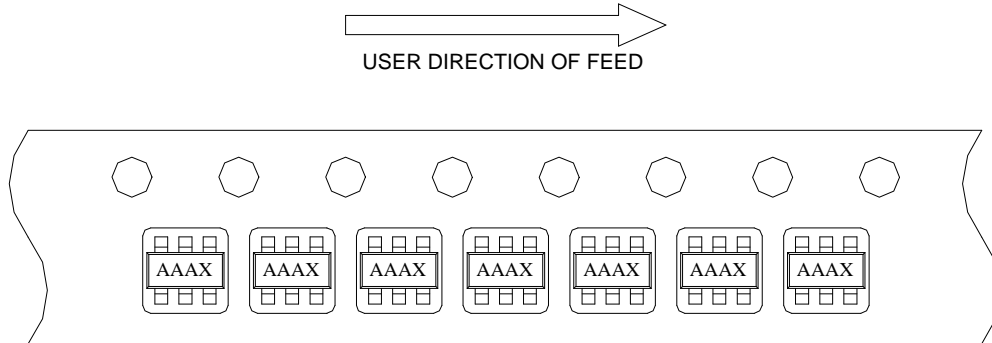

TDFN2x2-8

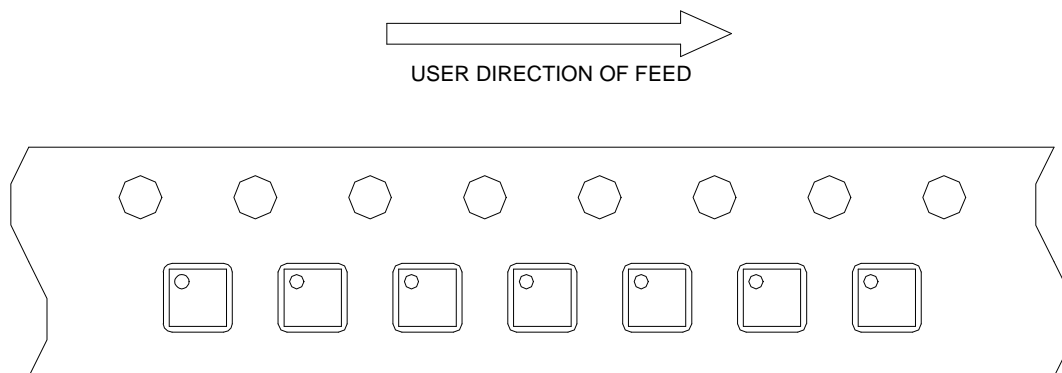

Classification Profile

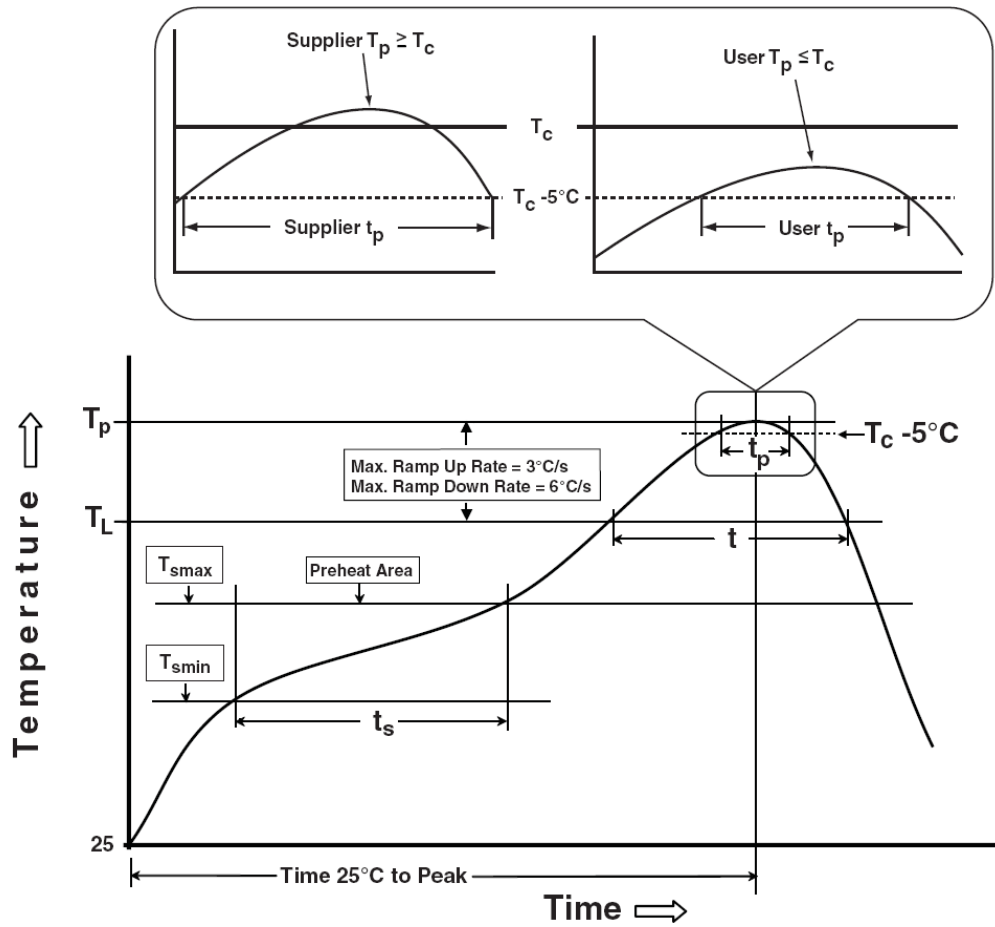

Classification Reflow Profiles

Profile Feature	Sn-Pb Eutectic Assembly	Pb-Free Assembly
Preheat & Soak		
Temperature min (T_{smin})	100 °C	150 °C
Temperature max (T_{smax})	150 °C	200 °C
Time (T_{smin} to T_{smax}) (t_s)	60-120 seconds	60-120 seconds
Average ramp-up rate (T_{smax} to T_p)	3 °C/second max.	3°C/second max.
Liquidous temperature (T_L)	183 °C	217 °C
Time at liquidous (t_L)	60-150 seconds	60-150 seconds
Peak package body Temperature (T_p)*	See Classification Temp in table 1	See Classification Temp in table 2
Time (t_p)** within 5°C of the specified classification temperature (T_c)	20** seconds	30** seconds
Average ramp-down rate (T_p to T_{smax})	6 °C/second max.	6 °C/second max.
Time 25°C to peak temperature	6 minutes max.	8 minutes max.
* Tolerance for peak profile Temperature (T_p) is defined as a supplier minimum and a user maximum.		
** Tolerance for time at peak profile temperature (t_p) is defined as a supplier minimum and a user maximum.		

Table 1. SnPb Eutectic Process – Classification Temperatures (T_c)

Package Thickness	Volume mm ³ <350	Volume mm ³ ≥350
<2.5 mm	235 °C	220 °C
≥2.5 mm	220 °C	220 °C

Table 2. Pb-free Process – Classification Temperatures (T_c)

Package Thickness	Volume mm ³ <350	Volume mm ³ 350-2000	Volume mm ³ >2000
<1.6 mm	260 °C	260 °C	260 °C
1.6 mm – 2.5 mm	260 °C	250 °C	245 °C
≥2.5 mm	250 °C	245 °C	245 °C

Reliability Test Program

Test item	Method	Description
SOLDERABILITY	JESD-22, B102	5 Sec, 245°C
HOLT	JESD-22, A108	1000 Hrs, Bias @ 125°C
PCT	JESD-22, A102	168 Hrs, 100%RH, 2atm, 121°C
TCT	JESD-22, A104	500 Cycles, -65°C~150°C
HBM	MIL-STD-883-3015.7	VHBM 2KV
MM	JESD-22, A115	VMM 200V
Latch-Up	JESD 78	10ms, 1 _{tr} 100mA

Customer Service

Anpec Electronics Corp.

Head Office :

No.6, Dusing 1st Road, SBIP,
Hsin-Chu, Taiwan, R.O.C.
Tel : 886-3-5642000
Fax : 886-3-5642050

Taipei Branch :

2F, No. 11, Lane 218, Sec 2 Jhongsing Rd.,
Sindian City, Taipei County 23146, Taiwan
Tel : 886-2-2910-3838
Fax : 886-2-2917-3838